

TAKEX PHOTOELECTRIC BEAM SENSOR [ANTI-CRAWL]

PB-100AT-KH

Instruction Manual

This product is a photoelectric beam sensor designed to be installed in a beam tower (sold separately).

The beam tower to be used is recommended to be rated IP 55 or better.

Please Note : This sensor is designed to detect intrusion and to initiate an alarm ; it is not a burglary or a crime preventing device. TAKEX is not responsible for damage, injury or losses caused by accident, theft, Acts of God (including inductive surge by lightning), abuse, misuse, abnormal usage, faulty installation or improper maintenance.

[FEATURE]

The PB-IN-100AT beam is equipped with many features which provide a wide choice of field selectable options. These options result in considerable flexibility for a variety of application requirements.

● Anti-crawling

PB-100AT-KH is designed to prevent a crawling intrusion to protected area by means of OR-gated detection in addition to AND-gated detection.

● Dual response time system

Two individual response times are provided for separate adjustment of AND/OR gates.

This enables detection of intruders with minimum false alarms.

(AND gated : Set at faster response time)
(OR gated : Set at slower response time)

● High power infrared

The active infrared transmission is exceptionally strong with a maximum arrival distance ten times greater than the specified protection distance.

● Four channel frequency selection

4 separate choices of frequency avoids cross-talk in stacked or long linear installations. Allows stacking of Transmitters or Receivers all on one side.

● Beam transmission strength selection

2 levels of beam transmission strength which can be set to suit the protection distance.

● Auto-gain lock

Optimal sensitivity gain is automatically set at any coverage distance up to the maximum protection distance. (Audible tone indicates setting is completed.)

● Environmental module

Environmental trouble signal is sent when beam reception level is reduced below an acceptable level.

● Programmed AGC function

Sensitivity is automatically increased in bad weather to contend with fog, rain, or frost.

● Audible signal for alignment

An alignment tone aids in quick set-up of beams for electrical measurement of alignment.

● Other features

Monitor output, Beam selector

[BASIC OPERATION DESCRIPTION]

This anti-crawl sensor was developed for high security applications to detect a crawling intrusion and are based on our PB-IN-HF series quad photoelectric beam sensors.

(Basic system)

Transmitters project separate double pulse modulated beams of different pulse pattern.

Receivers only respond to the individual transmitted beam.

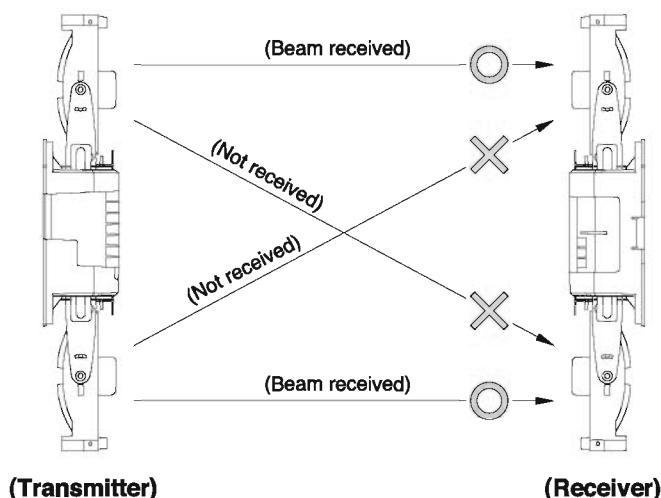

(Basic operation)

The following basic operation is required to detect a crawling intrusion and minimize false alarms.

Individual beam detection : An alarm is not initiated by instantaneous beam interruption, but an alarm is initiated when the interruption continues during a set response time. [OR gated]
The response time should be set at a time which will detect crawling intrusion and minimize false alarm risk due to small animals.

All beam detection : An alarm is initiated when both sets of beams are interrupted during a set response time. [AND gated]

- 1) Response timeSeparately adjustable for AND-gated or OR-gated on receiver unit.
- 2) 4 channel frequency selection is available. (Anti-crawl sensor can be used for multi-stacked / linear protection.)

1 PARTS DESCRIPTION

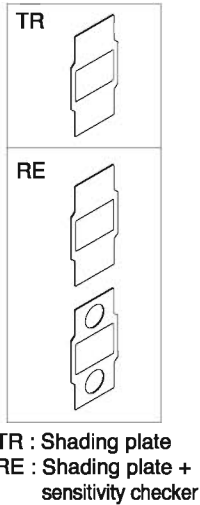
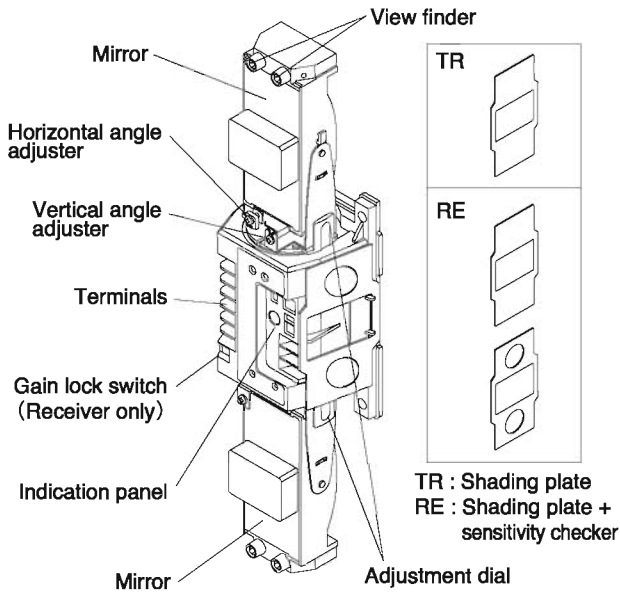

Accessories

- Panhead screw (M3X12) 8
- Lock spacer 1



Functions / Indications

[Transmitter]

- Operation LED
- Beam power (H set at factory)
- Beam channel frequency selectable switch (frequency 1-4) (1ch. set at factory)

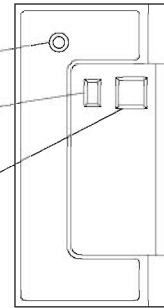

[Receiver]

- Sensitivity attenuation LED
- Alarm LED
- Beep (Alignment tone) switch (OFF set at factory)
- Response time adjustment [AND] (0.035sec. set at factory)
- Beam channel (frequency 1-4) (1ch. set at factory)
- Beam selector (upper set at factory)
- Response time adjustment [OR] (0.1sec. set at factory)
- Environmental output terminal

Monitor jack

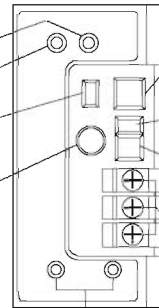

2 CAUTIONS ON INSTALLATION

1) DO'S AND DON'T'S



- Do not install the unit at places where it may be interrupted by obstacles such as trees.

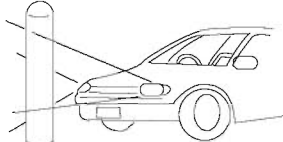

- Avoid strong light from the sun, automobile headlights etc. shining on transmitter and receiver directly. (Avoid light within $\pm 2^\circ$ degrees of optical axis.)



- Do not install the unit on unsteady surfaces.

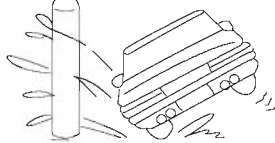

- Do not install the unit on places where it may be splashed by dirty water or direct ocean spray.

2) Protection distance

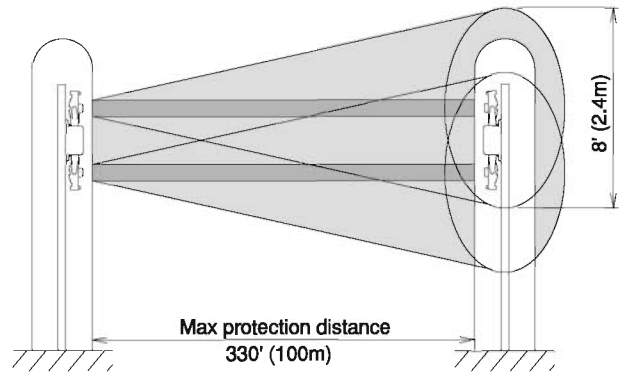

Wiring

The equipment must be powered from an LPS in accordance with EN60950-1 : 2001

1) Basic connection

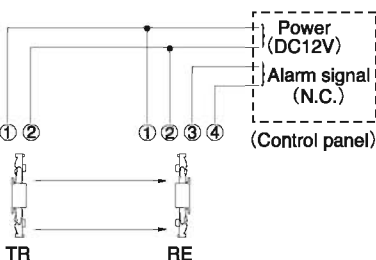

2) When two or more sensors are connected to the same line.

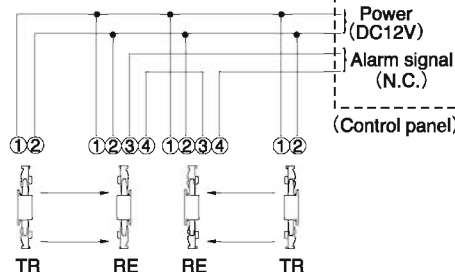

3) When two or more sensors are connected to separate lines.

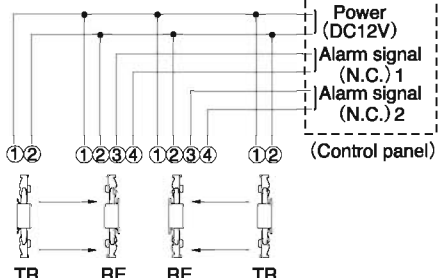

4) 2-stacked standard connection.

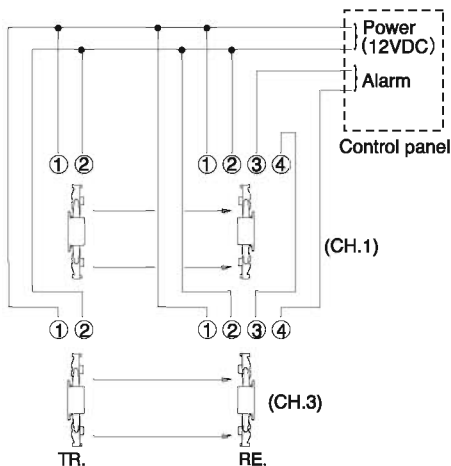

5) When environmental module is used.

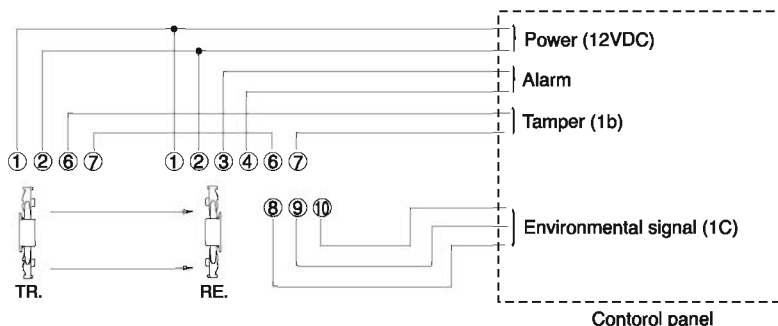

[Cautions on wiring]

- Signal output on receiver can not be used independently for the upper / lower optics, only as a set.
- Outdoor wiring should be in PVC if below ground or use direct burial cable. Conduit should be used for above ground wiring.

Note) Refer to 5. FUNCTIONS DESCRIPTION for beam channel (beam frequency selection).

6) Wiring Distance between sensor and control panel.

wire size \ voltage	12V	24V
AWG22 (Dia.0.65mm)	330' (100m)	2950' (899m)
AWG20 (Dia.0.8mm)	530' (160m)	5000' (1500m)
AWG18 (Dia.1.0mm)	830' (250m)	7200' (2200m)
AWG17 (Dia.1.1mm)	1000' (300m)	8800' (2680m)
AWG16 (Dia.1.25mm)	1350' (400m)	11500' (3510m)
AWG15 (Dia.1.4mm)	1750' (534m)	15500' (4730m)
AWG14 (Dia.1.6mm)	2150' (655m)	20000' (6000m)

Note 1)

Max. wiring distance when two or more sets are connected is the above value divided by the number of sets.

Note 2)

The signal line can be wired to a distance of up to approx. 3300' (1000m) with AWG 22 (Dia. 0.65mm) telephone wire.

*Standby battery

Be sure the control panel is equipped with adequate standby battery and charging circuit. Use 12V (at least) Nicd or lead acid battery with minimum capacity of 0.5AH.

—Estimated battery life—

No. of pair	Md AA 0.5AH	Gel Cell 1.0AH	Gel Cell 5.0AH
1	5 hr	11 hr	58 hr
2	—	5 hr	29 hr
4	—	—	14 hr
8	—	—	7 hr

- Unit should be connected to a listed, class 2 power source capable of providing standby power for a minimum of 4 hours.

3. Terminal arrangement

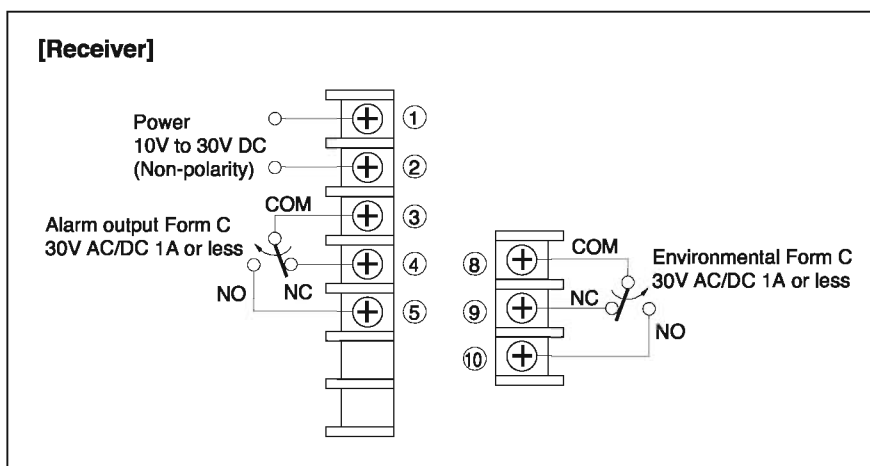
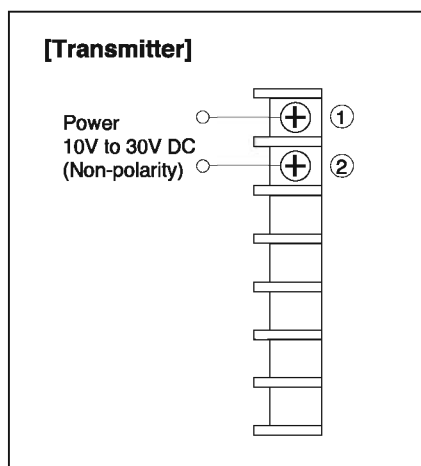

Mounting

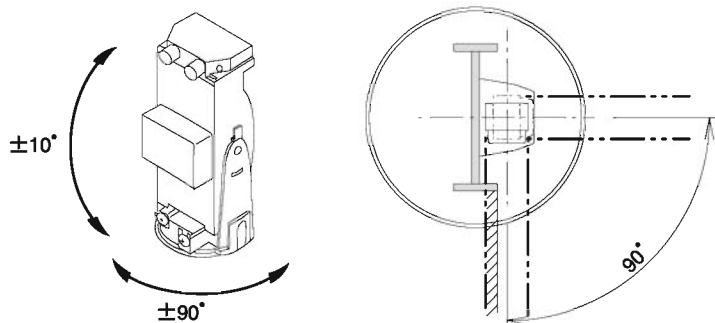

- Install the unit to a beam tower. Some towers could block the beam within its case when the mirror is turned by $\pm 90^\circ$ vertically. Please refer to the instruction manual of the beam tower carefully before use.

- Beam sensor's reflecting mirror can be moved horizontally (± 90 degrees) and vertically (± 10 degrees) allowing the unit to work in all directions.

3 SET-UP OF FUNCTIONS AND BEAM ALIGNMENT

- 1) Supply power with cover off.
- 2) Set function options.
(Refer to 5. FUNCTIONS DESCRIPTION for detailed explanation of each option.)

Location	Functions	Function Switches	
TR/RE	Beam channel (frequency)	<input type="checkbox"/> 1 ch. <input type="checkbox"/> 2 ch. <input type="checkbox"/> 3 ch. <input type="checkbox"/> 4 ch.	
TR. only	Beam power	<input type="checkbox"/> H <input type="checkbox"/> L	
RE. only	'Beep' alignment tone	<input type="checkbox"/> ON <input type="checkbox"/> OFF	
	Beam selector	<input type="checkbox"/> Upper <input type="checkbox"/> Lower	
	Response time adjustment	A	<input type="checkbox"/> 0.35sec. (standard)
		N	<input type="checkbox"/> 0.5sec. (MAX.)
O	<input type="checkbox"/> 0.1sec. <input type="checkbox"/> 0.2sec.		
	R	<input type="checkbox"/> 0.3sec. <input type="checkbox"/> 0.5sec.	

3) Adjust optical angle.

- 1) Look through view finder on either side of transmitter optical unit and move until receiver unit is visible.
- 2) Repeat the procedure for lower optical unit, and then repeat on receiver.

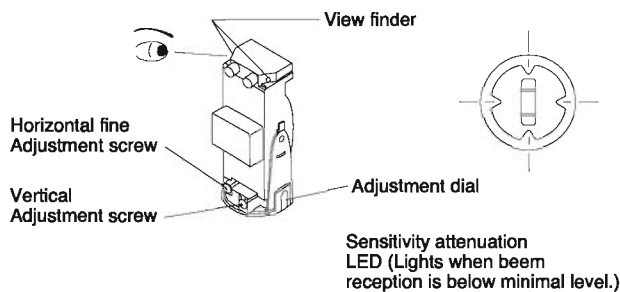

4) Fine tuning

Initial beam alignment can be achieved by using the alignment tone indicator.

- 1) Attached the shading plate (stored on side of TR) to lower optic of TR.
- 2) Set the beam selector at UPPER.
- 3) Attach the sensitivity checker (stored on side of RE) to the upper optic of RE.
- 4) Turn the receiver beep switch to ON.
- 5) Adjust the optics with the adjustment screws until highest tone is reached. (Note : There will be no sound if the attenuation LED is lit.)
- 6) Set the beam selector at LOWER.
- 7) Reverse the procedure and repeat adjustment.
- 8) After adjustment, replace the sensitivity checker in storage area of RE and turn the tone indicator off.

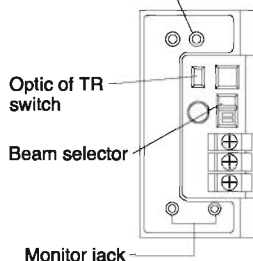

Readings for alignment are as follows.

Alignment	Voltage reading [With checker]
Best	1.8V or more
Good	1.4 to 1.8V
Poor, Re-adjust	1.4V or less

* When monitor output is 1.4V or less, adjust beam alignment again.

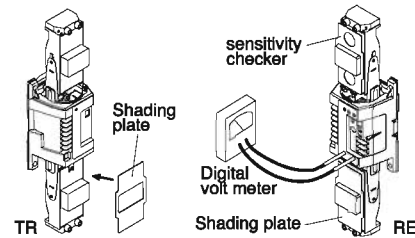

After initial beam alignment is completed, definitive alignment is achieved by using a voltmeter.

- 9) Set the beam selector at UPPER.
- 10) Attach the sensitivity checker to the upper optic of RE, and shading plate to the lower optic of RE.
- 11) Insert leads from voltmeter in monitor jacks of RE.
- 12) Check the voltage for the upper optics of RE.
- 13) Reverse the procedure and check the voltage for the lower optics of RE.
- 14) After adjustment, replace the shading plates and the sensitivity checker in the storage areas of transmitter and receiver.
- 15) After beam alignment, place the covers on the beam line. Then insert a lock spacer to the micro switch part for gain lock on the receiver unit.
- 16) 5sec. after, sensitivity margin will be automatically set and gain lock will be completed after beep sound is heard once.

If the beep sound is heard in an intermittent way, sensitivity is not good.

In this case, remove the lock spacer and adjust beam alignment again.

(Please refer to 5.3 Auto-gain lock function.)

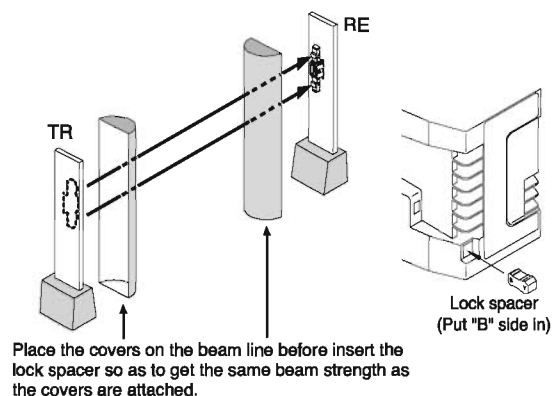

4 OPERATION CHECK

- 1) Alarm LED only.
- 2) Alarm LED and beep tone. (Walk test mode)
Set the beep switch to "ON", then a beep tone will be issued upon beam blockage for five minutes after the Auto gain is locked.

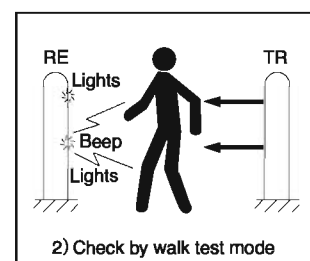
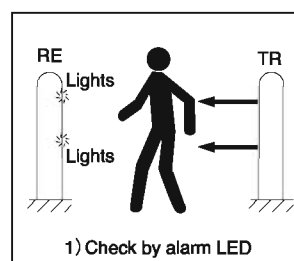

5 FUNCTIONS DESCRIPTION

1. Four channel frequency selection

The beam pairs may be set at various frequency levels to avoid crosstalk between units which are stacked, in-line, or other configurations which have the potential of spill-over transmission from one beam to another. Set the frequency level as illustrated.

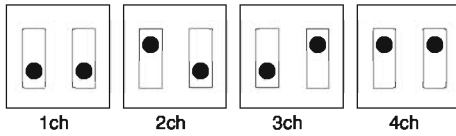

MAKE SURE TRANSMITTER AND RECEIVER OF PAIR ARE SET AT SAME CHANNEL ! Paired TR/RE will not set up unless set at the same channel.

1) Line protection

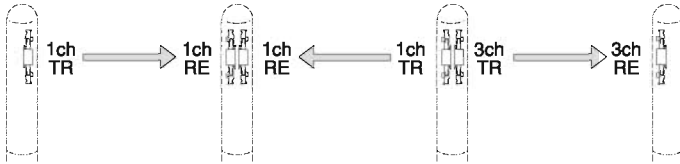

2) 2-stacked protection

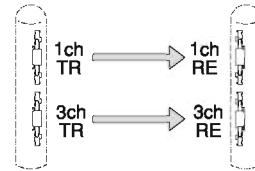

3) Line and 2-stacked protection

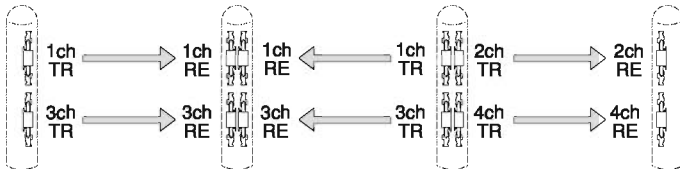

4) Perimeter protection

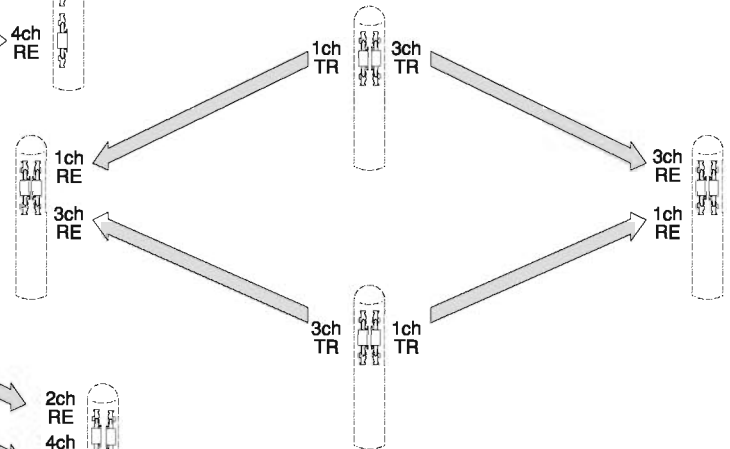

5) Perimeter double stacked protection

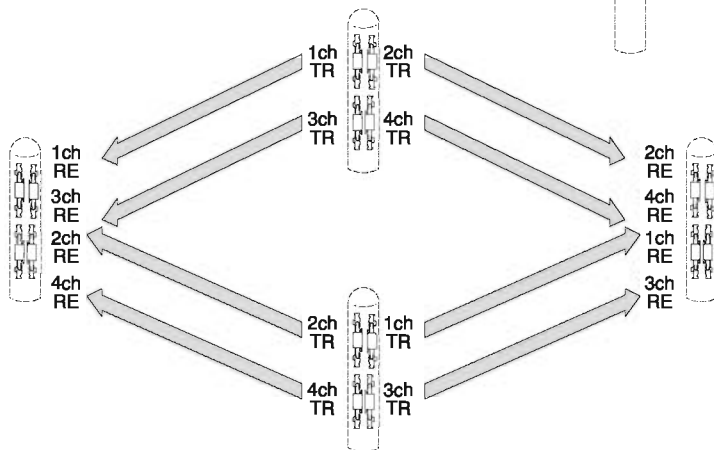

[Note]

The use of a voltmeter for alignment is advised to ensure highest level of stability. Do not fail to use PB-IN-100HF in combination with PB-IN-HF series when stacked installed (same directional transmission). The other models may cause malfunction.

2. Beam power selection

This option allows field selection of the appropriate beam intensity relative to the application. For distance significantly less than the specified protection distance, the beam intensity should be reduced to eliminate potential reflection problems. For zones reaching maximum protection distance, the beam level should be set to the highest level.

Note : For interior applications where greater chance for reflection occurs, the setting should be at LOW.

● H (set at factory)
○ L

H	Over 250' (75m) to 330' (100m)
L	250' (75m) or less

3. Auto-gain lock function

- 1) The auto-gain lock serves to standardize the responsiveness and tolerance level of the units regardless of varying distance in an installation.



The situations above have exactly the same tolerance and responsiveness levels even though the distance are different.

2) A "beep" tone is issued from the receiver approximately 5 seconds after the lock spacer is inserted into position. This tone indicates the Auto-gain has been set. Refer to the chart below.

Tone	Indicates	Result	Cause	Remedy
One pulse (Beep)	Optimal sensitivity has been set.	OK		
Continuous tone (20 seconds)	Optimal sensitivity can not be set.	NG	1. Beam is interrupted when a lock spacer is inserted. 2. Beams are mis-aligned and sensitivity attenuation LED lights.	1. Remove any blockage items or ensure hand is not breaking beam and insert a lock spacer again. 2. Check beam power setting at transmitter with cover off and re-adjust beam alignment.

Note 1) A tone is generated regardless of whether "beep" (alignment tone) switch is set to ON or OFF.

2) The auto-gain setting is locked in for approximately two weeks even if power is disrupted.

3) If the lock spacer is detached while power is supplied or if power is discontinued for longer than two weeks (but cover left in place), the auto-gain automatically reset to maximum sensitivity. (Gain is automatically locked with power re-supplied.)

4. Tone indicator

This feature provides audible testing or signals for the following items.

Test / Signal	Beep switch	Other condition	Description
Beam alignment	ON	Lock spacer detached.	●Reception strength monitored. Tone pitch increases as reception improves. (Note : No tone is given if sensitivity attenuation LED is lit or if receiver cover is attached.)
Walk test	ON	For approx. 5 min. after gain is locked.	●Tone is linked to alarm LED. Both trip simultaneously.
Auto-gain lock	ON or OFF	About 5sec. after the lock spacer is inserted	●Short tone indicates lock is set. Continuous tone (20sec.) indicates readjustment.

5. Response time changeover function (Dual response time system)

And-gated response time and OR-gated response time can be set separately.

- 1) An object passing through the beams faster than the set response time is undetected.
- 2) Adjust response time a little slower where the units may be affected by many birds.

Note) Set And-gated response time shorter (faster) than Or-gated response time.

And-gated (all beams interruption)

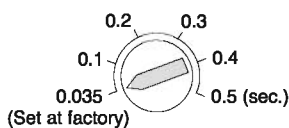

Response time adjustment (And)

Or-gated (either side beams interruption)

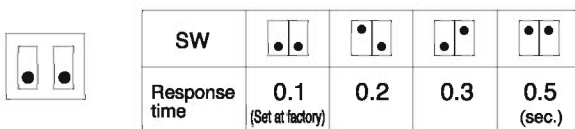

Response time adjustment (Or)

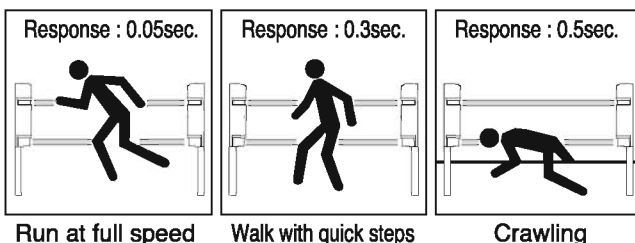

Run at full speed

Walk with quick steps

Crawling

6. Environmental Module

The environmental signal is initiated if the beam reception level is reduced to approx 25% or less.

The module "Watches" for a gradual degradation of the beam reception which is indicative of extremely poor weather conditions.

7. Beam selector

Use when beam alignment is adjusted.

Only the beam reception level of the beam that is selected by the beam selector is indicated on sensitivity attenuation LED, Sound check tone and monitor output.

When a lock spacer is inserted this function is canceled and sensitivity attenuation LED lights regardless of positioning of the selector even when either side of beam is attenuated.

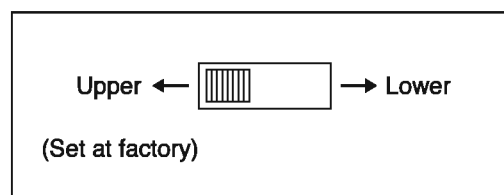

6 TROUBLESHOOTING

Symptom	Possible cause	Remedy
Operation LED does not light	<ol style="list-style-type: none"> 1. Disruption of power or inadequate power 2. Bad wiring connection or broken wire, short 	<ol style="list-style-type: none"> 1. Correct power source 2. Check and correct wiring
Receiver Alarm LED does not light when the beam is broken	<ol style="list-style-type: none"> 1. Disruption of power or inadequate power 2. Bad wiring connection or broken wire, short 3. Reflection of beam is flooding receiver and sent into the receiver 4. Beam interruption time is shorter than response time 	<ol style="list-style-type: none"> 1. Correct power source 2. Check and correct wiring 3. Remove reflecting object. Set beam power to Low. Contact Pulnix for further remedies 4. Adjust response time
Receiver Alarm LED stays lit	<ol style="list-style-type: none"> 1. Alignment is off 2. Shading object between transmitter and receiver 3. Optics of units are soiled 4. Frequency channel setting on transmitter does not match with that on receiver 	<ol style="list-style-type: none"> 1. Check and adjust 2. Check site / remove any possible obstacles 3. Clean the optics with a soft cloth 4. Readjust to be the same channel
Intermittent alarm	<ol style="list-style-type: none"> 1. Bad wiring connection 2. Change of supply voltage 3. Shading object between transmitter and receiver 4. The wiring of power machine is located nearby transmitter and receiver 5. Unstable installation of transmitter and receiver 6. Optics of units are soiled 7. Improper alignment 8. Small animals may pass through the 4 beams 9. Beam power switch is set at L, which does not keep enough sensitivity allowance 	<ol style="list-style-type: none"> 1. Check again 2. Stabilize supply voltage 3. Remove the shading object 4. Change the place for installation 5. Stabilize 6. Clean the optics with soft cloth 7. Check and re-adjust 8. Change environments or the place for installation 9. Set beam power switch at H and make the unit gain-locked with receiver cover detached

(Units should be tested on a regular weekly basis)

7 SPECIFICATIONS

Model	PB-100AT-KH
Detection system	Near infrared beam interruption system (TR,-RE 4 beams simultaneous interruption or upper 2 beams interruption or lower 2 beams interruption)
Infrared beam	Double modulation pulsed beam by LED
Protection distance	Outdoor 330' (100m) or less
Max. arrival distance	Tenfold 3300' (1000m)
Response time	Dual response time system 0.035-0.5sec. (AND gated) 0.1, 0.2, 0.3, 0.5sec. (OR gated)
Power supply	10V to 30V DC (non-polarity)
Current consumption	85mA or less at protection (Max. 120mA or less)
Alarm output	Dry contact relay 1c Reset : Interruption time + off-delay (approx. 1.5 sec.) Contact capacity : 30V AC / DC, 1A or less
Environmental output	Dry contact relay : 1c Contact operation : Output when weather condition gets worse Contact capacity : 30V AC / DC, 1A or less
Alarm LED	Red LED (receiver) lights when an alarm is initiated
Sensitivity attenuation LED	Red LED (receiver) lights when beam reception is attenuated
Functions	Modulated beam frequency selection, Tone indicator, Environmental module, Beam power selection, Beam selector, Programmed AGC. Auto-gain lock function, Monitor jack.
Beam adjustment	Horizontal : $\pm 90^\circ$, Vertical : $\pm 10^\circ$
Ambient temperature range	-31°F to $+151^\circ\text{F}$ (-35°C to $+66^\circ\text{C}$)
Mounting position	Beam tower
Wiring	Terminals
Weight	Transmitter : 10.6 oz (300g) Receiver : 14.1 oz (400g)
Appearance	ABS resin

8 EXTERNAL DIMENSIONS

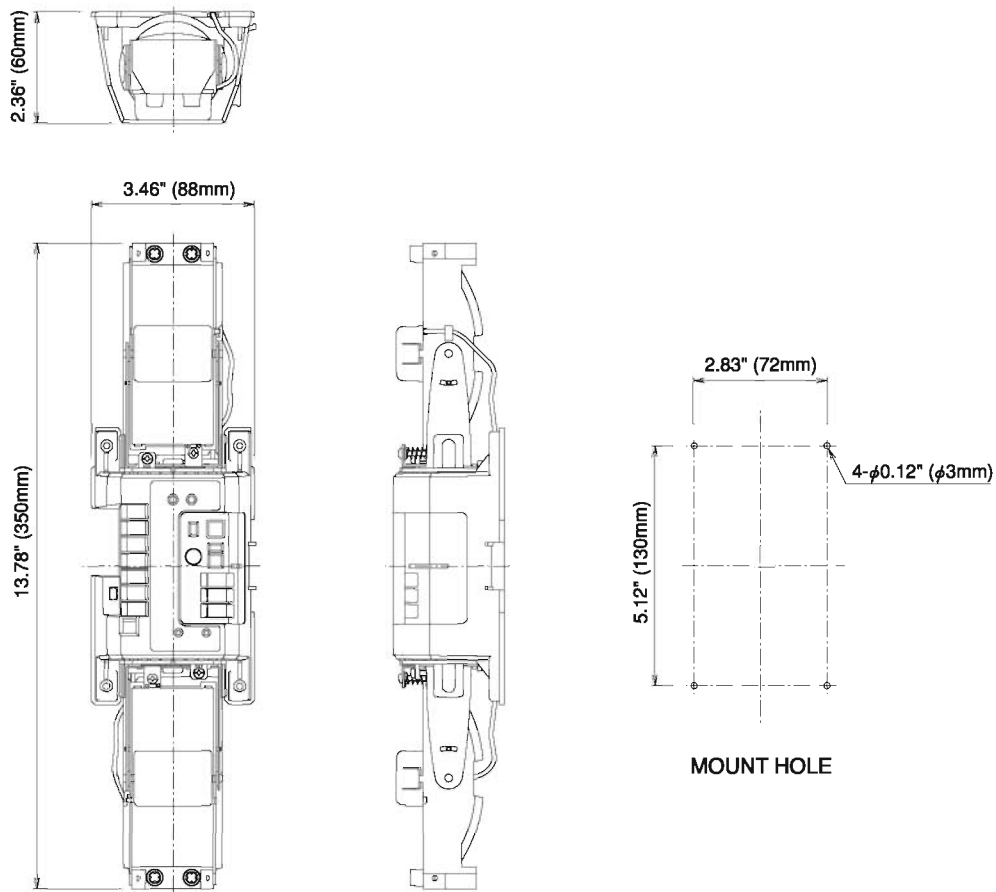

9 SPECIAL NOTES

This equipment has been tested and found to comply with the limits for a Class B digital device, pursuant to part 15 of the FCC Rules. These limits are designed to provide reasonable protection against harmful interference in a residential installation. This equipment generates, uses and can radiate radio frequency energy and, if not installed and used in accordance with the instructions, may cause harmful interference to radio communications. However, there is no guarantee that interference will not occur in a particular installation. If this equipment does cause harmful interference to radio or television reception, which can be determined by turning the equipment off and on, the user is encouraged to try to correct the interference by one or more of the following measures :
 —Reorient or relocate the receiving antenna. —Increase the separation between the equipment and receiver. —Connect the equipment into an outlet on a circuit different from that to which the receiver is connected. —Consult the dealer or an experienced radio / TV technician for help.

WARNING : Changes or modifications not expressly approved by the party responsible for compliance could void the user's authority to operate the equipment.

Limited Warranty :

TAKEX products are warranted to be free from defects in material and workmanship for 12 months from original date of shipment. Our warranty does not cover damage or failure caused by Acts of God (including inductive surge by lightning), abuse, misuse, abnormal usage, faulty installation, improper maintenance or any repairs other than those provided by TAKEX. All implied warranties with respect to TAKEX, including implied warranties for merchantability and implied warranties for fitness, are limited in duration to 12 months from original date of shipment. During the Warranty Period, TAKEX will repair or replace, at its sole option, free of charge, any defective parts returned prepaid. Please provide the model number of the products, original date of shipment and nature of difficulty being experienced. There will be charges rendered for product repairs made after our Warranty period has expired.

TAKENAKA ENGINEERING CO., LTD.

In Japan

Takenaka Engineering Co., Ltd.
 83-1, Gojo-sotokan, Higashino,
 Yamashina-ku, Kyoto 607-8156, Japan
 Tel : 81-75-501-6651
 Fax : 81-75-593-3816
<http://www.takex-eng.co.jp>

In the U.S.

Takex America Inc.
 3350 Montgomery Drive, Santa
 Clara, CA 95054, U.S.A.
 Tel : 408-747-0100
 Fax : 408-734-1100
<http://www.takex.com>

In Australia

Takex America Inc.
 Unit 16/35 Garden Road, Clayton,
 3168 Victoria, Australia
 Tel : 03-9546-0533
 Fax : 03-9547-9450

In the U.K.

Takex Europe Ltd.
 Takex House, Aviary Court, Wade Road,
 Basingstoke, Hampshire. RG24 8PE, U.K.
 Tel : (+44) 01256-475555
 Fax : (+44) 01256-466268
<http://www.takexeurope.com>