

# NE-DC Series

## Embedded Amplifier Photo Sensors

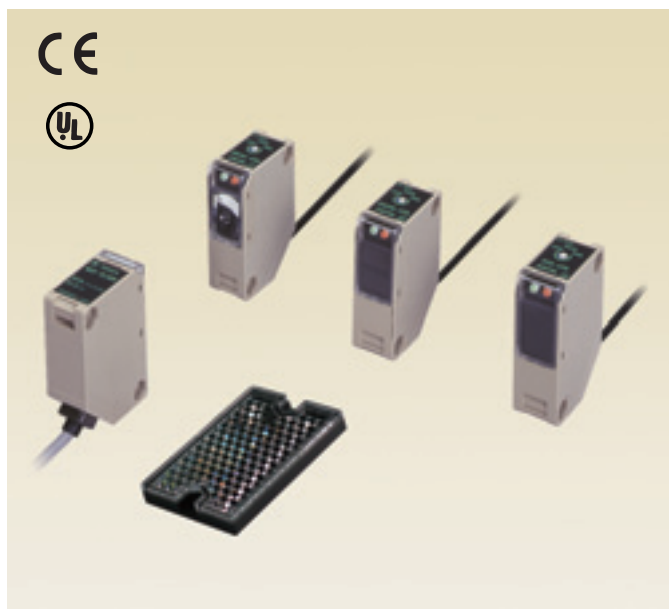

- Longest-in-class detecting distance  
(30 m with through-beam style sensor)  
Through-beam type: 10 m, 30 m  
Reflector type: 5 m  
Diffuse-reflective type: 1 m
- Polarization reflector method reliably detects mirror-like objects
- Red LED light source for ease of adjustment  
(through-beam 10 m model, polarization reflector model)
- External light emission stop input feature is convenient for checking "before" operation, prevention of interference and timing (through-beam type only)
- Polarization filter (separately available) for adjacent mounting of 2 units (through-beam type NE-T10RD-DC)

### Type

Detection method	Detecting distance	Model		Light source	Output mode
		Dark-ON mode	Light-ON mode		
Through-beam type	10m	NE-T10RD-DC	NE-T10R-DC	Red LED	NPN/PNP open collector
		NE-T10RD-DC-J	NE-T10R-DC-J		
	30m	NE-T30D-DC	NE-T30-DC	Infrared LED	
		NE-T30D-DC-J	NE-T30-DC-J		
Polarization reflector type	0.03~5m	NE-M5RD-DC	NE-M5R-DC	Red LED	
		NE-M5RD-DC-J	NE-M5R-DC-J		
Diffuse-reflective type	1m	NE-R10D-DC	NE-R10-DC	Infrared LED	
		NE-R10D-DC-J	NE-R10-DC-J		

### Optional Parts

Type	Model	Applicable model	Description
Pinhole plate	NE-P3	NE-T10R (D) -DC NE-T30 (D) -DC	Hole diameter $\phi$ 3 } Detecting distance with plate attached P.262
	NE-P5		
	NE-P5 $\times$ 1		
Reflector	K-71	NE-M5R (D) -DC	Detecting distance: 0.03-2m
	K-2		Detecting distance: 0.3-3m
	S-510G		Detecting distance: 0.1-3m
Interference prevention filter	NE-PFA	NE-T10R (D) -DC	Longitudinal polarization filter
	NE-PFB		Horizontal polarization filter
Mounting bracket	NE-B1	All models	Vertical mounting
	NE-B2		Back-to-back mounting
Cord with M8 connector	FBC-4R2S	Permanently attached cord with connector (-J) type	M8 straight (2m)
	FBC-4R2L		M8 angled (2m)

## Rating/Performance/Specification

Model	NE-T10RD-DC ※	NE-T30D-DC ※	NE-M5RD-DC	NE-R10-DC
Detection method	Through-beam type		Polarization reflector type	Diffuse-reflective type
Detecting distance	10m max.	30m max.	0.03~5m max. *1	1m max. *2
Detection object	φ 20mm (Min.) Opaque		Mirror-like objects (Note)/opaque objects/translucent objects	Opaque objects/translucent objects (Note 1)
Power supply	12-24V DC ±10% / Ripple 10%			
Current consumption	Transmitter: 5 mA max. Receiver: 15 mA max.	Transmitter: 20 mA max. Receiver: 15 mA max.	22mA max.	26mA max.
Output mode	NPN/PNP open collector 2 outputs Rating: 100 mA, (30 VDC) max. *3			
Operation mode	Dark-ON *4			Light-ON *5
Light emission stop function	Provided (no-voltage input)		—————	
Response time	1ms max.		0.5ms max.	
Hysteresis	—————			10% max.
Operating angle	3° (at receiver)	5° (at receiver)	30° (reflector)	—————

\*Set model No. Transmitter model: NE-TL10R-DC Receiver model: NE-TR10RD-DC

Transmitter model: NE-TL30-DC Receiver model: NE-TR30D-DC

\*1 With reflector model K-7 (accessory)

\*2 With standard detection object (200 x 200 mm white drawing paper)

\*3 NPN: sink current; PNP: source current

\*4 Light-ON type available

\*5 Dark-ON type available

Light source	Red LED (700nm)	Infrared LED (880 nm)	Red LED (700nm)	Infrared LED (880 nm)
Indicator	Transmitter: power indicator (red LED) *6 Receiver: operation indicator (red LED) Stability indicator (green LED)		Operation indicator (red LED) Stability indicator (green LED)	
Volume	—————		Sensitivity adjustment	
Material	Lens: Acrylic Case: heat-resistant ABS			
Connection *7	Permanently attached cord Transmitter: 0.3 sq. 3 core 2 m length Receiver: 0.3 sq. 4core 2 m length		Permanently attached cord Transmitter: 0.3 sq. 4 core 2 m length	
Mass	About 130 g (transmitter/receiver)		About 130 g	
Accessory *8	—————		K-7 reflector	—————
Notes	Light-ON type Model NE-T10R-DC	Light-ON type Model NE-T30-DC	Light-ON type Model NE-M5R-DC	Dark-ON type Model NE-R10D-DC

\*6 Not provided for transmitter model NE-TL 10R-DC

\*7 Connector type separately available (-J type: cord length 0.3 m)

\*8 Mounting brackets are not provided. See Dimensions.

## Environmental Specification

Ambient light	10,000 lx max.
Ambient temperature	-25 - +55°C (non-freezing)
Ambient humidity	35~85%RH (non-condensing)
Protective structure	IP66
Vibration	10-55 Hz / 1.5 mm amplitude / 2 hours each in 3 direction
Shock	100 m/s <sup>2</sup> / 3 times each in 3 directions
Dielectric withstanding	500 VAC for 1 minute
Insulation resistance	500 VDC, 20 MΩ or higher

(Note) Some materials do not allow stable detection. Mirror-like objects wrapped in transparent film, glossy objects, laminated aluminum nameplates, etc., may inherently affect polarization. In such cases, the polarized waves of the sensor may be disturbed, which causes unstable detection.

(Note 1) Detecting objects with higher transmission may offer shorter detecting distances.

# NE-DC

## Input/Output Circuit and Connection

Transmitter

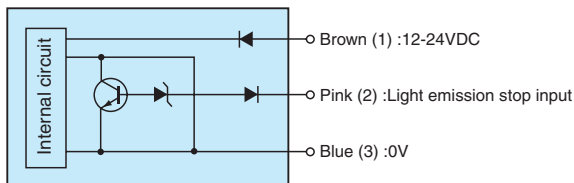

Receiver/sensor

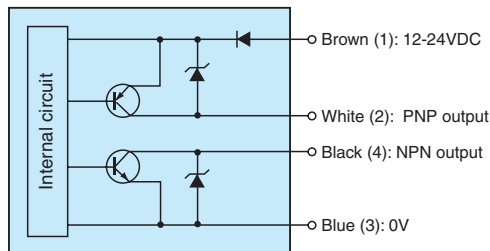

## Connection

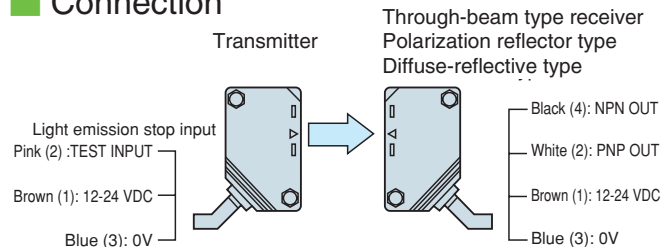

- The output transistor turns off when load short circuit or overload occurs. Check the load and turn the power back on.
- Circled numbers show connector pin Nos. for -J type.

## Directional characteristics (Typical Example)

NE-T10R (D) -DC (-J)

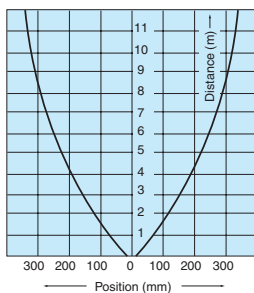

NE-M5R (D) -DC (-J)

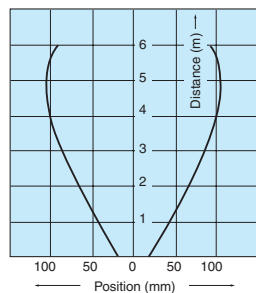

## Activation area characteristics (Typical example)

NE-R10 (D) -DC (-J)

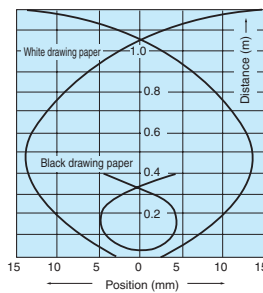

## Distance-area characteristics (Typical example)

NE-R10 (D) -DC (-J)

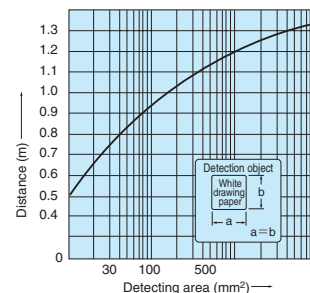

## Pinhole Plate (optional)

Pinhole plates as described below are available for through-beam type models. Use of pinhole plates reduces the smallest allowable detection object diameter and activation area.

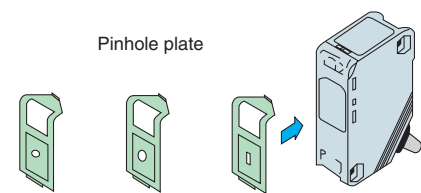

NE-P3 (φ 3)    NE-P5 (φ 5)    NE-P5×1 (5×1mm)

Detecting distance with plates attached to both transmitter and receiver

Sensor model	Pinhole plate model		
	NE-P3	NE-P5	NE-P5×1
NE-T10R(D)-DC	1m	3m	0.7m
NE-T30(D)-DC	3m	7m	2m

## Detecting Distances for Different Reflectors (Model: NE-M5RD-DC)

The detecting distance depends on the reflector used.

Reflector model	Detecting distance
K-7 (Accessory)	0.03-5m
K-71	0.03-2m
K-2	0.1-3m
S-510G	0.1-3m

## Indicators

- Light axis alignment and sensitivity adjustment are simple. Setting within the stable range increases the reliability against variation of environment after setting.
- The operation indicator (red LED) and stability indicator (green LED) respectively show different received light intensity levels as described in the figure.

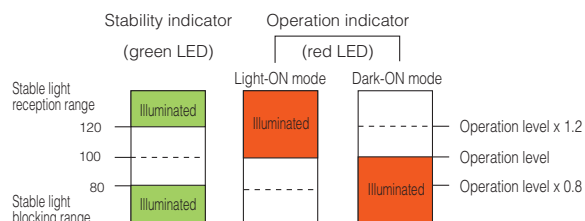

## Dimensions (in mm)

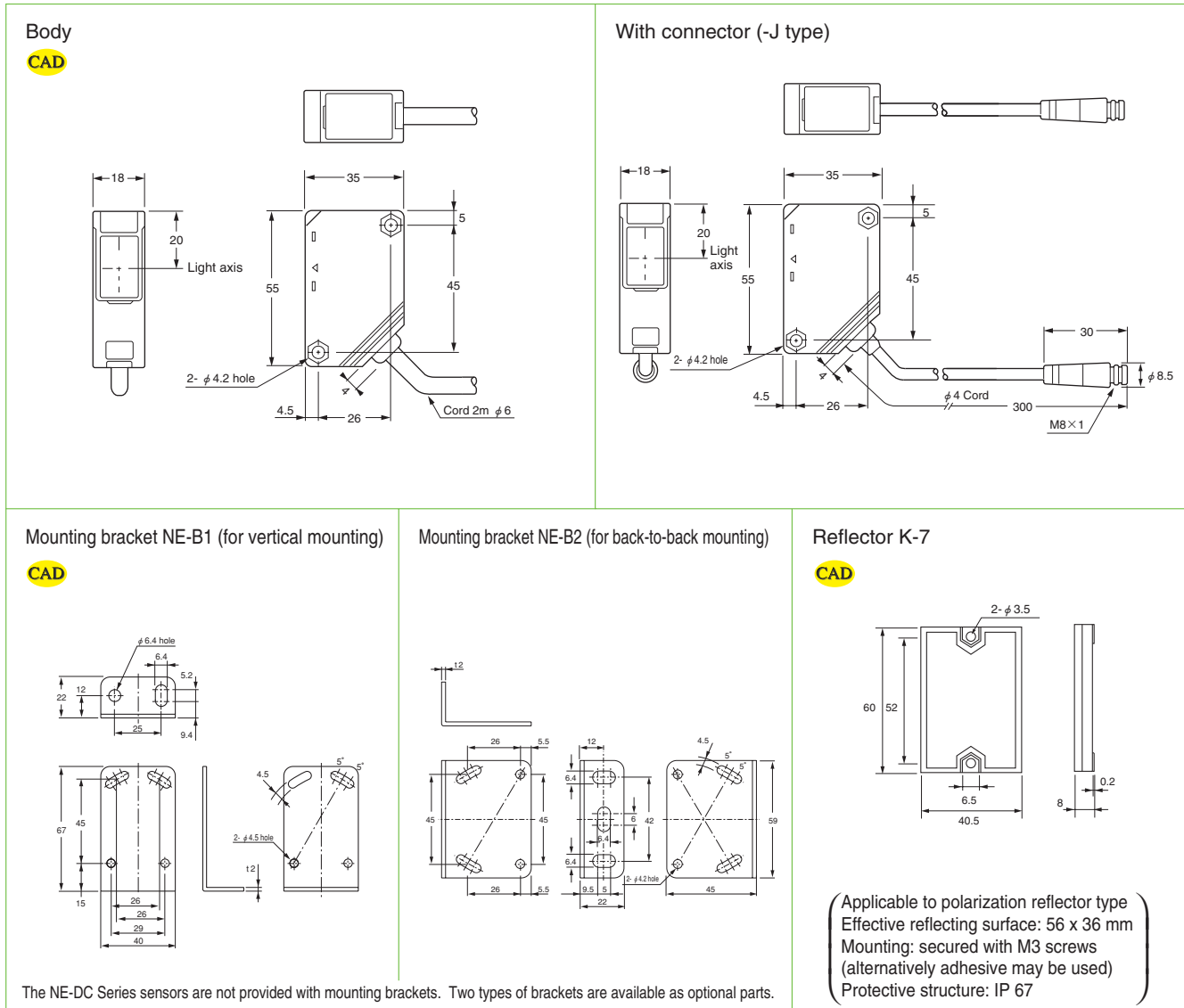

## Attachment of Interference Prevention Filter (optional)

Model  
NE-PFA (longitudinal type)  
NE-PFB (horizontal type)

Use of filters allows adjacent mounting of through-beam type sensors.  
For adjacent mounting of two sensors, use the longitudinal type for one pair and horizontal type for the other.

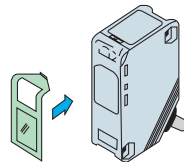

Insert into grooves at the top and bottom of the lens side of the transmitter and receiver.

Attach NE-PFA

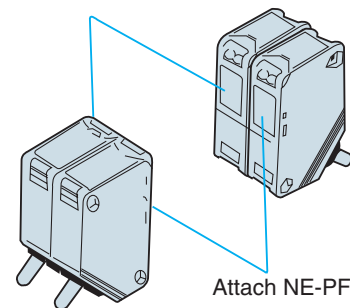

Attach NE-PFB

May be attached to model NE-T10R (D).  
The detecting distance with the filters attached is up to 5 m.

## For Correct Use

- Avoid turning power "On and Off" consecutively.
- Do not use output signals in the transient condition while the power is turned on/off.
- The tightening torque for the sensor body and mounting bracket should not exceed 0.8 N·m max.
- While this product has a waterproof structure (IP 66), do not use in a place subject to constant water spray or under water. Also note that use in a place subject to corrosive gas, vibration/shock or direct splash of oils/chemicals may lead to faulty operation.